

KID CURATOR & THE MEMORIAL PLAQUE

This video is part of a series, created as a collaboration between Michael Mills and the History Trust of South Australia. The Kid Curator series explores local South Australian history through historical objects. The videos provide a curatorial description of the object and period in history blended with narrative-based re-enactments. Each video focuses on an object from the History Trust of South Australia's State History Collection and provides differing points of view on the history of the object in question. View the video and use the dedicated education resource for a cross curricular exploration of the history of South Australia.

The Memory Cove Plaque

This video showcases the Memory Cove Plaque which is currently displayed at the South Australian Maritime Museum. The plaque was ordered to be made and erected in the place now known as Memory Cove by Mathew Flinders. It was South Australia's first European memorial and perhaps the first physical object left by Europeans on southern soil. The video considers the perspective of a First Nations man and of Matthew Flinders.

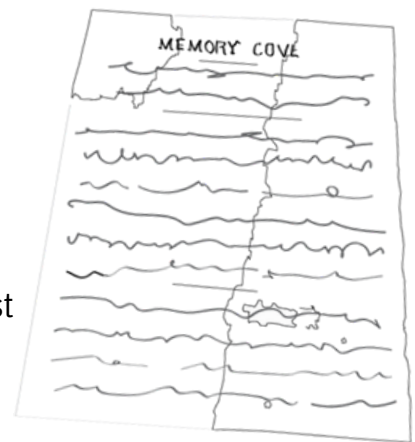

Curriculum Map

Year 4

Art – explore where, why and how visual arts are created and/or presented across cultures, times, places and/or other contexts (AC9AVA4E01) use visual conventions, visual arts processes and materials to create artworks that communicate ideas, perspectives and/or meaning (AC9AVA4C01)

HPE – explain how and why emotional responses can vary and practise strategies to manage their emotions (AC9HP4P06)

Year 5

Art – explore ways that visual conventions, visual arts processes and materials are combined to communicate ideas, perspectives and/or meaning in visual arts across cultures, times, places and/or other contexts (AC9AVA6E01) use visual conventions, visual arts processes and materials to plan and create artworks that communicate ideas, perspectives and/or meaning (AC9AVA6C01)

HPE – apply strategies to manage emotions and analyse how emotional responses influence interactions (AC9HP6P06)

Year 6

Art – explore ways that visual conventions, visual arts processes and materials are combined to communicate ideas, perspectives and/or meaning in visual arts across cultures, times, places and/or other contexts (AC9AVA6E01) use visual conventions, visual arts processes and materials to plan and create artworks that communicate ideas, perspectives and/or meaning (AC9AVA6C01)

HPE – apply strategies to manage emotions and analyse how emotional responses influence interactions (AC9HP6P06)

Focus Questions

Before watching:

1. What does the word memorialise mean?
2. Have you ever seen a plaque in a public place? What was written on it?
3. Do all communities use plaques to remember people?
4. What is the importance of a name?

After watching:

1. What things do we do to remember people that used to be in our lives?
2. Why is it significant that Flinders chose to use copper for the plaque?
3. What do you know about how cultures memorialise people differently?

Class Activity

Memory Box Makers

As a class, think about these questions:

- 1) How do you keep memories safe?
- 2) How can we help others keep their memories safe?

First, using the template provided, create a design on the inside and outside of your memory box. Your design should represent your learning, thinking and feelings from this day.

Next cut out the template and fold all of the lines.

Take some time to collect the items you would like to store inside the memory box. It could be things such as drawings, notes or other small, long-lasting items that remind you of today. Try to include objects that use your five senses.

Finally, construct your box using glue or tape making sure to add the items before sealing.

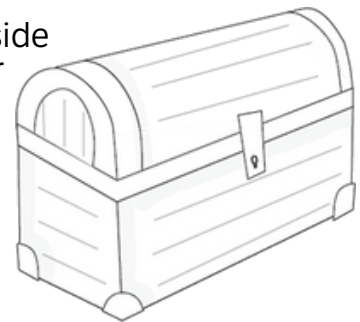

Where to Next?

Research further into the importance of symbols and memorialisation using a resource like this one:

<https://www.scottle.edu.au/ec/viewing/L9511/index.html>

